

Contents

- | | |
|---|--|
| <ol style="list-style-type: none"> 1. Introduction 2. International Telegraph Union 3. International Telecommunication Union 4. Components of Digital Telecommunication 5. How Digital Communication works? 6. Why Digital transmission is better than the Analog Transmission? 7. Transmission Media 8. Why a pair of wires is used? Why not single? 9. Why twisted pairs are kept in cables? Why not untwisted? 10. Data Transmission 11. Optical Fiber System 12. How are optical fibers different from ordinary cables? 13. What are advantages of Optical Fiber Communication? 14. Glass or Plastic Optic Fiber. Which is Better? 15. Single-Mode and Multimode Fibers 16. Can we use Optical Fibers in Power transmission? 17. Unguided Media 18. Electromagnetic Spectrum 19. Radio waves 20. Understanding the Radio Spectrum 21. What is sweetspot in Radio Spectrum? 22. What are Bands and Channels? 23. How Radio waves Propagate? 24. Ground waves 25. Why only lower frequencies propagate via ground wave? 26. Line of Sight 27. Skywave 28. How Radio sets work? 29. Why the frequency of FM Radio generally ranges between 90 and 110 MHz? 30. All radio receptions except FM band are affected when cable TV is switched on. Why? | <ol style="list-style-type: none"> 31. Why transistor radio gives a clear and loud reception when the antenna is held or touched by hand? 32. Microwaves 33. Why Microwaves are considered better than Radio waves for safer communication? 34. Use of Microwaves: 35. Infrared Waves 36. Applications of Infrared: 37. How the Night vision devices work? 38. What is difference between night vision and thermal imaging? 39. What are Heat seekers? 40. How Remote Controls work? 41. Mobile Telephony 42. Brief History (from wikipedia) 43. Development of 1G, 2G and 3G 44. GSM Standards 45. Architecture of GSM 46. Does GSM allow signals when we travel in aeroplane? 47. Code Division Multiple Access (CDMA) 48. Advantages and Disadvantages of CDMA 49. Bluetooth 50. Why Blue, why not any other color? 51. Why Bluetooth? 52. Does Bluetooth interfere with other systems? 53. What is spread-spectrum frequency hopping? 54. What is Bluetooth Piconet? 55. Advantages of Bluetooth 56. What is Bluejacking? 57. Wi-Fi 58. WiMax 59. Broadband Wireless Spectrum 60. Long-Term Evolution (LTE) 61. LTE v/s WiMax |
|---|--|

Introduction

Telecommunication refers to the transmission of information over significant distances to communicate. In older times, the telecommunication used visual signals, such as beacons, smoke signals, signal flags, and optical heliographs. We have been told about the use of the pigeons, coded Drumbeats, sounds of conch shells, lung blown horns, loud cries and whistles in the historic era, all are examples of the telecommunication.

In the today's era of electricity and electronics, telecommunications usually includes electrical devices such as telegraphs, telephones, Mobiles, teleprinter, radio, Microwave and infrared communications apart from the fibre optics, internet and satellites.

This document deals specifically with the following:

- ✓ Electromagnetic waves
- ✓ Radio
- ✓ Television
- ✓ Landline Telephones
- ✓ Mobile Telephony & Wireless Telecommunication
- ✓ Internet, Use of Fiber Optics.
- ✓ Satellite Communications

-: About this document:-

It's worth note that in the first decade of 20th century, pioneering developments in wireless radio communications by Nikola Tesla and Guglielmo Marconi took place. Marconi won the Nobel Prize in Physics in 1909 for his efforts. Other highly notable pioneering inventors include:

- Charles Wheatstone and Samuel Morse (telegraph)
- Alexander Graham Bell (telephone)
- Edwin Armstrong, and Lee de Forest (radio)
- John Logie Baird and Philo Farnsworth (television).

The rapid progress of the Information & Communication Technology has opened opportunities to attain higher levels of developments in them. The obstacles of time and distance have almost been removed and millions of people are getting benefitted by it. ICT has been able to contribute in the generation of jobs, economic growth and increasing the productivity. ICT has been able to give a better opportunity to create dialogues among the countries and Civilizations.

It was in May 1844, when On 24 May 1844. Samuel Morse sent his first public message over a telegraph line" between Washington and Baltimore in the USA, thus creating the single-wire telegraph system based on European telegraphs and ushered the world into the telecommunication age. Today, Samuel Morse is best known for the **Morse code** which refers to transmitting textual information as a series of on-off tones, lights, or clicks that can be directly understood by a skilled listener or observer without special equipment., co-inventor. **Morse code was the primordial binary information.**

International Telegraph Union

It took just a decade to make the telegraphy a service available to the general public. Here it would be better if we recall how International communication took place at that era. Today we are able to communicate in real time without many hassles because of the "uniform standards" adopted. But at that time, every country used its own set of standards and before the message was to sent to another country it needed to translated and transliterated.

This was cumbersome process and then to make things easy to do, some European countries came together and to develop a framework agreement covering international communication.

So, now the rules to standardize the equipments to facilitate the communication were to come up. It was in 1865, when the first International Telegraph Convention was signed in Paris by the 20 countries and thus was formed the International Telegraph Union (ITU).

International Telecommunication Union

The International Telecommunication Union was established in 1934 as a successor to all the previous agencies in the area of telecommunications including International Telegraph Union. It is based in Geneva, Switzerland, and in 1947 became the member of the United Nations Development Group. Today, it has 192 member states and some seven hundred sector members and associates. **Today it is the specialized UN agency.**

The objective of setting up the ITU was to establish and maintain international cooperation for expansion and rational use of telecommunication and work towards making it available to public.

Components of Digital Telecommunication

The modern telecommunication systems have the following components

- Hardware: such as computer, modems, Radio Sets, Mobile Phones, Television sets etc.
- Media: the wired or wireless media via which the signals are transmitted.
- Networks: network between the devices.
- Protocols: These are the rules that govern the transmission of the signals
- Software that controls the systems.

We have already read above that the information is translated in the form of signals which can be analog or digital. The analog signals are still used but the digital communications have gradually outdated them.

-: About this document:-

Digital systems have many advantages over analog systems. Digital systems provide significantly better clarity for images, data and text, because they can be represented in the digital signals and in that of binary format. This possibility of converting all information in binary format has made it technologically possible to merge TV, Phones, Internet and other services.

The communication is now possible with more speed, accuracy and flexibility similar to comparing CDs with LP recordings.

Digital Communications	
Advantages	Disadvantages
<ul style="list-style-type: none"> Reliable communication; less sensitivity to changes in environmental conditions (temperature, etc.) Easy multiplexing Easy signaling Hook status, address digits, call progress information Voice and data integration Easy processing like encryption and compression Easy system performance monitoring Integration of transmission and switching 	<ul style="list-style-type: none"> Increased bandwidth 64 KB for a 4 KHz channel, without compression (However, less with compression) Need for precision timing Bit, character, frame synchronization needed Analogue to Digital and Digital to Analogue conversions Higher complexity

How Digital Communication works?

The Telecommunications devices first covert the different types of information such as video, audio, images, texts etc. into electronic or optical signals. This signal is passed through a **source encoder**.

The source encoder has a number of formulas to reduce the redundant binary information. Then the digitized signal is processed in a **channel encoder**. The channel encoder introduces redundant information that allows errors to be detected and corrected. Thus, now the signal is encoded. This encoded signal is made suitable for transmission by modulation. The modulation begets the carrier wave. This carrier can be made a part of larger signal which is called Multiplexing. This multiplexed signal is sent into a multiple access transmission channel.

The process is reversed after the transmission. The information is extracted and the device at the receiving end converts the signal back into voice / video or data.

The digital communication makes it possible to send a message from one sender to single receiver or one sender to multiple receivers. They are called point-to-point and point-to-multipoint. **The Point-to-multipoint telecommunications are known as broadcasts.**

Why Digital transmission is better than the Analog Transmission?

Please note that in analog communication, the signal, whose amplitude varies continuously, is transmitted over the medium. Reproducing the analog signal at the receiving end is very difficult due to **transmission impairments**.

So, the analog communications systems are badly affected by **noise**. Its worth note that the electrical signal output from a transducer such as microphone, or a video camera is an analog signal, which means that the amplitude of the signal varies continuously with time. Transmitting this signal (with necessary transformations) to the receiving end results in an analog transmission.

However, at the receiving end, it has to be ensured that the signal does not get distorted due to transmission impairments. This is the most difficult part of the analog transmissions.

The output of the computer is a digital signal which has a fixed number of the amplitude levels. For example, a binary 1 can be represented by one voltage level (e.g. 5 volts) and binary 0 can be represented by another level (e.g. 0 volts). If this signal is transmitted over the medium with necessary info, the receiving end needs to detect ONLY these voltage levels and thus the signal is impaired to a lesser extent. Unless the signal is badly damaged, the receiving end can identify the amplitude levels.

GUIDED MEDIA

Transmission Media

In the data transmission system, the transmission media is the physical path between the sender and receiver or the transmitter or receiver. **There are two types of the transmission media viz. guided and unguided.** The Guided medium requires the **physical link** between the transmitter and receiver and follows a

-: About this document:-

predefined specific physical path such as cable or wire. The Unguided media does not require the physical link such as Radio transmission.

The cables are best examples of guided media which are most commonly used in LAN. The type of the cable may be dependent upon the network topology, protocol and also the network size. Accordingly the cables are of the following types:

- ✓ Unshielded Twisted Pair (UTP)
- ✓ Shielded Twisted Pair (STP)
- ✓ Coaxial
- ✓ Fiber Optic

Thus we see that the twisted cables come into two forms viz. UTP and STP. UTP cables are found in many Ethernet networks and telephone systems. For indoor telephone applications, UTP is often grouped into sets of 25 pairs according to a standard 25-pair color code originally developed by AT&T. A typical subset of these colors (white/blue, blue/white, white/orange, orange/white) shows up in most UTP cable. Twisted pair cables are often shielded in an attempt to prevent electromagnetic interference. Because the shielding is made of metal, it may also serve as a ground. However, usually a shielded or a screened twisted pair cable has a special grounding wire added called a drain wire.



Please note that Electromagnetic shielding is the process of reducing the electromagnetic field by blocking the field with barriers made of conductive and/or magnetic materials. Electromagnetic shielding that blocks radio frequency electromagnetic radiation is also known as RF shielding.

Why a pair of wires is used? Why not single?

Please note that in wire transmission, an electromagnetic wave is guided along a wire conductor to a receiver. The propagation of wave is accompanied by electric current through the conductor. Since all practical conductor materials possess some electrical resistance, part of the electric current is always lost by conversion to heat, which is radiated from the wire. This loss leads to the distortion of the electromagnetic signal. The amount of this distortion increases linearly with increasing distance between the transmitter and the receiver.

The bundled pair of conductors provides the current path and return path and mostly copper is used because of its high tensile strength and low resistance. Two wires carry equal and opposite signals and the destination detects the difference between the two. This is known as differential mode transmission.

Why twisted pairs are kept in cables? Why not untwisted?

This is a fundamental but very important question. Please note that twisting is an extremely difficult way to send the high speed signals down a cable because most electrical noise entering into and / or radiating from the cable is eliminated by twisting. Further, the cross leaking between wires in a cable is also minimized.

But the question is why there is a leakage? This is because that in addition to the energy flowing down a wire, it can flow between wires due to the electrostatic and magnetic effects that occur when the voltages or current in the wires change. This can lead to leakage or "cross talk" as they say it. The signals are sent down the twisted pair wires in such a way that one wire becomes positive and another becomes negative by the same amount. The other wires in the vicinity of this pair will be affected by the cross talk equal to the sum of these two signals which is zero.

Then we have the Coaxial cables, which are known as Coax. Coax refers to the common axis of the two conductors. A coaxial cable has a single copper conductor at its center. There is a plastic layer that provides insulation between the center conductor and a braided metal shield. The metal shield helps to block any outside interference from the fluorescent lights etc. the structure of Coaxial cable is shown as below:

-: About this document:-

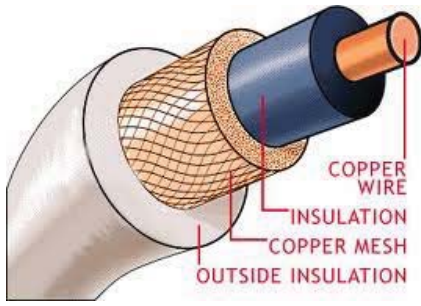

Please note that coaxial cable is highly resistant to signal interference. It can support greater cable lengths between the network devices than the twisted pair cable.

There are two types of the coaxial cables viz. Thick Coaxial and thin Coaxial. It has different specifications, which have witnessed the development of Ethernet standards. For instance, in 1979 Xerox defined the first official standard specification for Ethernet. This Ethernet Version 1.0 was capable of transferring data at 10Mb/s over fairly thick (10mm diameter) 50W coaxial cable. It was called 'Thick Ethernet' or '10Base5'. The meaning of

10Base5 is that it allowed a 10Mb/s data rate; it used baseband transmission rather than a modulated high-frequency carrier, and would give reliable data communication over cable lengths up to 500 meters.

A few years later, the 802.3 working group of the IEEE (Institution of Electrical and Electronics Engineers) released its first industry standard for Ethernet, giving it the name IEEE 802.3 Carrier Sense Multiple Access with Collision Detection (CSMA/CD) Access Method and Physical Layer Specifications. This was the refined version of DEC-Intel-Xerox Thick Ethernet.

Please note that in a coaxial cable, the electromagnetic field propagates within the dielectric insulator, while the associated current flow is restricted to adjacent surfaces of the inner and outer conductors. This is the reason that the coaxial cables have very low radiation losses and low susceptibility to the external interferences.

Data Transmission

There are two types of data transmission over the cables viz. Baseband and Broad band. Baseband refers to the analog transmissions with each wire carrying a single signal, while the Broadband refers to the digital transmission with wires carrying several signals at the same time.

Optical Fiber System

We all know that Light plays a vital role in our daily lives. In the compact discs, light is used in which a laser reflecting off a CD transforms the returning signal into music. Further, in the grocery stores we see the use of optical laser in reading the barcode for prices. Similarly, light is the core of recording images on paper by the laser printer.

The optical fiber is the medium for carrying the information from one point to another in the form of light. So, the first character is that they are NOT electrical in nature like the copper wires. A basic fiber optic system consists of a transmitting device that converts an electric signal into in light signal and a receiver that accepts the light signal and converts it back to the electric signal. The Optic Fiber System may be from very simple to extremely sophisticated systems. A simple system is shown below:

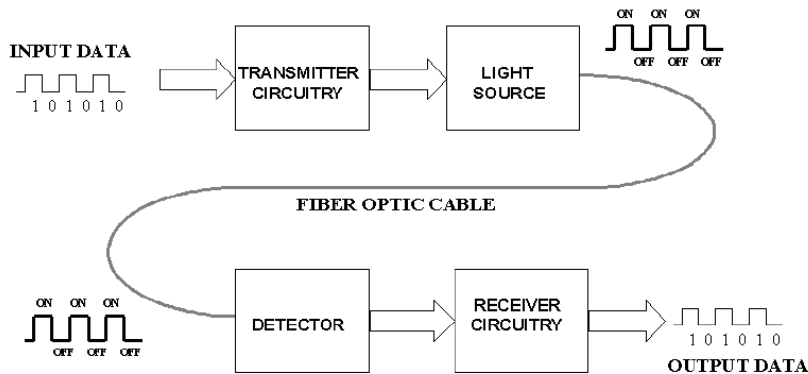

-: About this document:-

Today, the long-distance telephone cable has now been replaced by Optical Fiber Cable. From the decades of 1980s onwards there has been phenomenal growth in the use & importance of Fiber Optic System.

How are optical fibers different from ordinary cables?

The difference is that signals are transmitted as light in optic communication. Conventional electronic communication relies on electrons passing through wires. Since fibers transmit signals as light rather than current, they are **immune to electromagnetic interference** which causes noisy data transmission in wires. Because of this, they are used where data security is critical.

- ✓ As no shielding is required against electromagnetic interference, they are smaller and more flexible, which makes installation much easier than metal cables.
- ✓ Fiber optic cable is more efficient than other cables as it has **lower attenuation**, mainly because light is not radiated out in the way that electricity is radiated from copper cables
- ✓ Non-conductive nature of fibers avoids spark hazards and damage to electronic equipment from power surges.
- ✓ They can transmit signals at higher speeds or over long distances.
- ✓ Copper wires are adequate for the vast bulk of computer data transmission over point to point links and local area networks. They react differently to tension as they are elastic and copper is inelastic.
- ✓ Optical fibers can be used to sense, illuminate, deliver laser power, display and image as well as to communicate. One disadvantage is that they are more expensive than other cables.

In an optical fiber the light signal undergoes total internal reflection. The light hits the fibers at the glancing angle and is transmitted forward. They have different layers of glass protected in layers of buffers, namely, hard buffer, soft buffer, core glass, and cladding glass. The cladding glass has a low refractive index toward the core glass. When total internal reflection occurs the signal is transmitted. The soft and the hard buffer are protective coating which provide the necessary protection to the inner glass from external environments.

Please note that Optical communication employs a beam of **modulated monochromatic light** to carry information from transmitter to receiver. The light spectrum spans a tremendous range in the electromagnetic spectrum, i.e. extending from the region of (10^4 gigahertz to 10^9 gigahertz) covering the far infrared to visible to near ultraviolet.

What are advantages of Optical Fiber Communication?

- ✓ There is enormous **potential bandwidth**. The optical fiber carrier frequency has far greater potential transmission than the metallic cable systems.
 - ✓ The Optical fibers are in smaller diameters and lighter than the corresponding cable wires.
 - ✓ Optical fibers which are fabricated from glass or sometimes the plastic polymers are electrical insulators and don't exhibit the interface problems or earth loop. So, this property makes them suitable for use in electrically hazardous environments. There are no spark hazards and short circuit issues.
 - ✓ The light from optical fiber does not radiate significantly and thus provides a **high degree of data security**.
 - ✓ There is low transmission loss.
 - ✓ The Optical Fibers are potentially a low cost solution in comparison to the metallic wires.
- Some disadvantages
- ✓ Higher initial cost
 - ✓ Higher maintenance cost.

The Optical Fibers are basically very thin strands of pure glass and many of them have diameter of a human hair. Most of them are made from **silica** but other materials such as **fluorozirconate, fluoroaluminate, and chalcogenide** glasses are also used for making optical fibers for longer-wavelength infrared or other specialized applications. Then some other crystalline materials like **sapphire** are also used in making of Optical Fibers.

All of us know that Optical fibers work on Total Internal Reflection. The refractive index of silica is about 1.5, but some materials such as the chalcogenides can have indices as high as 3. They are arranged in bundles called optical cables and used to transmit light signals over long distances. If we look at a single optical fiber, we see its three parts viz. Core, Cladding and Buffer Coating.

-: About this document:-

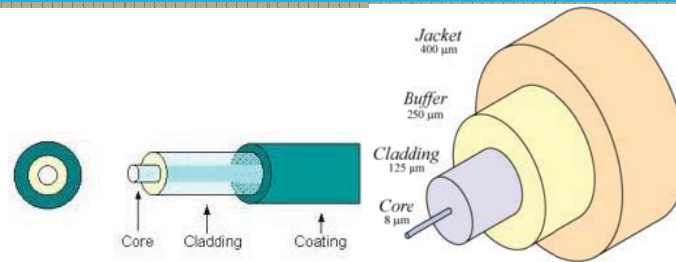

The Core is a thin glass center of the fiber where the light travels, the typical width is 8μm. The Cladding is outer optical material surrounding the core that reflects the light back into the core, typically with a width of 125μm. The Buffer coating is a Plastic coating that protects the fiber from damage and moisture. Its width is 250μm. The outermost layer is jacket. Typically the index difference between core and cladding is less than one percent.

Glass or Plastic Optic Fiber. Which is Better?

In the making of the Optical Fibers, the attenuation coefficients also matters. The attenuation coefficient is a quantity that characterizes how easily a material or medium can be penetrated by a beam of light, sound, particles, or other energy or matter. A large attenuation coefficient means that the beam is quickly "attenuated" (weakened) as it passes through the medium, and a small attenuation coefficient means that the medium is relatively transparent to the beam. The Plastic optical fibers (POF) have higher attenuation coefficients than glass fibers and that is why high attenuation limits the range of POF-based systems.

In comparison Silica shows extremely low absorption and scattering losses of the order of 0.2 dB/km and has a fairly broad glass transformation range. Silica fiber also has high mechanical strength against both pulling and even bending, provided that the fiber is not too thick and that the surfaces have been well prepared during processing. Silica is also relatively chemically inert. In particular, it is not hygroscopic (does not absorb water), thus is comparatively better.

But as above mentioned, the silica has a refractive index of 1.5. For enhancing the quality of the Optical Fiber, the refractive index of the Silica is increased. The method is doping with other materials. These materials include the Germanium dioxide (GeO2) or Aluminum oxide (Al2O3). In certain situations, doping may also be used to lower the reflective index. The material typically used for lowering the refractive index is fluorine or Boron trioxide (B2O3)

However, still attenuation cannot be eliminated completely. We take a question here:

Consider the following:

1. Total Internal Reflection
2. Scattering
3. Absorption

The attenuation in Optical Fibers is caused because of which among the above?

Answer: Attenuation is an important factor limiting the transmission of a digital signal across large distances. Thus, much research has gone into both limiting the attenuation and maximizing the amplification of the optical signal. Empirical research has shown that attenuation in optical fiber is caused primarily by **both scattering and absorption**

The Optical cables contain hundreds or thousands of these optical fibers, protected by the cable's outer covering, called a jacket. There are two types of the Optical Fibers viz. Single-mode fibers and Multi-mode fibers. The Single-mode fibers have small cores (about 3.5 x 10⁻⁴ inches or 9 microns in diameter) and transmit infrared laser light (wavelength = 1,300 to 1,550 nanometers). Multi-mode fibers have larger cores (about 2.5 x 10⁻³ inches or 62.5 microns in diameter) and transmit infrared light (wavelength = 850 to 1,300 nm) from light-emitting diodes (LEDs).

Before we go ahead, lets recall that the refractive index of a medium is (n) is defined as follows:

$$n = c/v$$

Where c is near 3x10⁸ meter per second, refers to speed of light in free space and v is speed of light in that particular medium.

-: About this document:-

The light in a fiber-optic cable travels through the core by constantly bouncing from the cladding due to total internal reflection. When light passes from a medium with one index of refraction (m_1) to another medium with a lower index of refraction (m_2), it bends or refracts away from an imaginary line perpendicular to the surface (normal line).

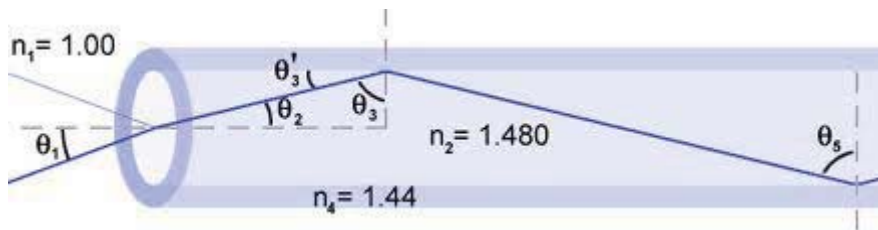

As the angle of the beam through m_1 becomes greater with respect to the normal line, the refracted light through m_2 bends further away from the line. At one angle which is known as Critical angle, the refracted light will not go into m_2 , but instead will travel along the surface between the two media (sine [critical angle] = n_2/n_1 where n_1 and n_2 are the indices of refraction [n_1 is greater than n_2]). If the beam through m_1 is greater than the critical angle, then the refracted beam will be reflected entirely back into m_1 (total internal reflection), even though m_2 may be transparent.

- ✓ Thus, The reflective index of Clad is always lower than that of core to enable this.

Single-Mode and Multimode Fibers

There are two general categories of optical fiber: single-mode and multimode. Multimode fiber allows hundreds of modes of light to propagate through the fiber simultaneously. Additionally, the larger core diameter of multimode fiber facilitates the use of lower-cost optical transmitters.

On the other hand, the single mode fiber allows only one mode of light at a time to propagate and thus has smaller core.

Can we use Optical Fibers in Power transmission?

Yes. By using the photovoltaic cell. The optical fiber can be used to transmit power using a photovoltaic cell to convert the light into electricity, but it is NOT very efficient method. So, it is used in certain situations where it is desirable not to have a metallic conductor. Examples are devices used close to MRI machines, which produce strong magnetic fields.

UNGUIDED MEDIA

The unguided media is the wireless media or still media where signals travels thru the air, space etc. The applications of unguided media are so much that it has been subject to an array of regulation, licensing, standardization of transmissions. The typical unguided media are Radio waves, Satellites and Microwaves. Before we go ahead, we need to understand the Electromagnetic spectrum.

Electromagnetic Spectrum

When light is passed through a prism, it is separated into all colors of rainbow, which is known as visible spectrum. The initial explanations of light said that light consists of tiny particles which they call photons, which travel at a speed of light☺. When these particles hit something, they get bounced, absorbed or reflected back. When the bounce off from something and enter our eyes, we are able to see something.

The above descriptions could not satisfactorily explain why some photons are absorbed and others are reflected.

The theory of Electromagnetic spectrum tried to solve this dilemma. It is based upon the hypothesis that light is made up of waves. This theory has been used to explain that longest wavelength of the visible light

-: About this document:-

(red) and shortest wavelengths of the visible light (blue) are absorbed by the green leaves (Chlorophyll) and green light is let reflected so that leaves appear green.

However, there are some properties of light which can be explained by particle nature and other by wave nature. The electromagnetic spectrum incorporates the range of all electromagnetic radiation, and extends from electric power at the long-wavelength end to gamma radiation at the short-wavelength end. In between, we find radio waves, infra-red, visible light, ultra violet and X-rays used in medical diagnostics. The following graphics shows the general properties of all the wavelengths of the electromagnetic spectrum. All of them are commonly known as Electromagnetic waves.

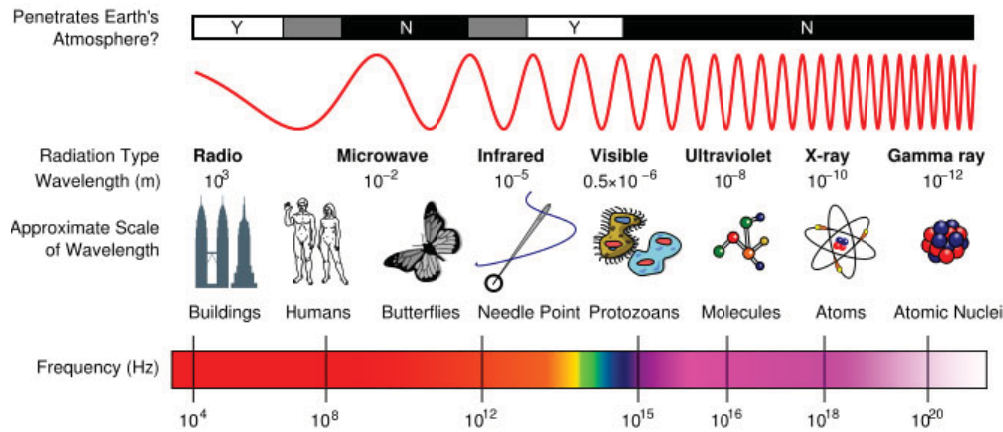

Image: Wikimedia Commons

Electromagnetic waves are defined by their special characteristics, such as frequency, wavelength and amplitude.

Frequency

The frequency refers to the number of waves generated in a set period of time and is measured in Hertz (Hz). 1 Hz means one wave per second, 1 kHz (kilohertz) means one thousand waves per second, 1 MHz (megahertz) means one million waves per second, 1 GHz (gigahertz) means one billion waves per second and so on.

Wavelength

Wavelength is the distance between two waves. There is a fixed mathematical interrelation between the frequency and the wavelength. The higher frequencies have shorter wavelengths and the lower frequencies have longer wavelengths. The wavelength also indicates the ability of the wave to travel in space. A lower frequency wave can reach longer distances than a higher frequency wave. Radio waves are usually specified by frequency rather than wavelength.

RADIO WAVES

Radio waves are waves with wavelengths longer than infrared light. Like all other electromagnetic waves, they travel at the speed of light.

- ✓ The lightning and astronomical objects make the naturally occurring radio waves.

The artificially generated radio waves are used for fixed and mobile radio communication, broadcasting, radar and other navigation systems, satellite communication, computer networks and other applications.

- ✓ Different frequencies of radio waves have different propagation characteristics in the Earth's atmosphere.
- ✓ Different parts of radio spectrum are allocated to the various services.
- ✓ The shortest Radio wavelengths are of a few millimeters while the longest radio waves are several kilometers in length.

-: About this document:-

- ✓ Radio waves were first predicted by mathematical work done in 1865 by James Clerk Maxwell.
- ✓ In 1887, Heinrich Hertz demonstrated the reality of Maxwell's electromagnetic waves by experimentally generating radio waves in his laboratory.

Understanding the Radio Spectrum

Part of the electromagnetic spectrum corresponding to **radio frequencies** is called Radio Spectrum. The radio-frequency spectrum (which is simply referred to as spectrum) is only a comparatively small part of the electromagnetic spectrum, covering the range from 3 Hz to 300 GHz. It includes a range of a certain type of electromagnetic waves, called radio waves, generated by transmitters and received by antennas or aerials. The frequencies in the Radio Spectrum is lower than around 300 GHz, which corresponds to wavelengths longer than about 1 mm.

Band

A small section of the spectrum of radio communication frequencies, in which channels are usually used or set aside, is called a Band.

Classification

To prevent interference and allow for efficient use of the radio spectrum, similar services are allocated in bands. For example, broadcasting, mobile radio, or navigation devices, will be allocated in **non-overlapping** ranges of frequencies. There are **12 bands** as per the provisions of the ITU as follows:

ITU Radio Bands			
Band Number	Symbols	Frequency Range	Wavelength Range
1	ELF	3 to 30 Hz	10,000 to 100,000 km
2	SLF	30 to 300 Hz	1000 to 10,000 km
3	ULF	300 to 3000 Hz	100 to 1000 km
4	VLF	3 to 30 kHz	10 to 100 km
5	LF	30 to 300 kHz	1 to 10 km
6	MF	300 to 3000 kHz	100 to 1000 m
7	HF	3 to 30 MHz	10 to 100 m
8	VHF	30 to 300 MHz	1 to 10 m
9	UHF	300 to 3000 MHz	10 to 100 cm
10	SHF	3 to 30 GHz	1 to 10 cm
11	EHF	30 to 300 GHz	1 to 10 mm
12	THF	300 to 3000 GHz	0.1 to 1 mm

- ✓ So, when we move from ELF to THF, the frequency range increases
- ✓ When we move from ELF to THF, the wavelength decreases.

However, the above table gets significantly changed when we refer to the Institute of Electrical and Electronics Engineers (IEEE) specifications. The IEEE has divided the Radio Frequency spectrum into 13 bands starting from the lowest frequency **HF Band** to Highest Frequency **mm Band** as follows:

IEEE Radio Spectrum Bands (from wikipedia)		
Band	Frequency range	Origin of name
HF band	3 to 30 MHz	High Frequency
VHF band	30 to 300 MHz	Very High Frequency
UHF band	300 to 1000 MHz	Ultra High Frequency
L band	1 to 2 GHz	Long wave
S band	2 to 4 GHz	Short wave
C band	4 to 8 GHz	Compromise between S and X
X band	8 to 12 GHz	Used in WW II for fire control, X for cross (as in crosshair)
Ku band	12 to 18 GHz	Kurz-under
K band	18 to 27 GHz	German Kurz (short)
Ka band	27 to 40 GHz	Kurz-above

-: About this document:-

V band	40 to 75 GHz	
W band	75 to 110 GHz	W follows V in the alphabet
mm band	110 to 300 GHz	

But the Radio Society of Great Britain divides these frequencies as follows:

Designation	Frequency range
L band	1 to 2 GHz
S band	2 to 4 GHz
C band	4 to 8 GHz
X band	8 to 12 GHz
Ku band	12 to 18 GHz
K band	18 to 26.5 GHz
Ka band	26.5 to 40 GHz
Q band	33 to 50 GHz
U band	40 to 60 GHz
V band	50 to 75 GHz
E band	60 to 90 GHz
W band	75 to 110 GHz
F band	90 to 140 GHz
D band	110 to 170 GHz

We see that the above classifications of different radio bands have been done on the basis of the wavelength / frequency. On the basis of broadcasting, frequencies the Radio spectrum has been divided into the following parts:

1. Longwave AM Radio = 148.5 – 283.5 kHz (LF)
2. Mediumwave AM Radio = 530 kHz – 1710 kHz (MF)
3. Shortwave AM Radio = 3 MHz – 30 MHz (HF)

The radio spectrum has the excellent ability to carry codified information (signals) and that is why it is home of communication technologies such as mobile phones, radio and television broadcasting, two-way radios, broadband services, radar, fixed links, satellite communications, etc. Radio spectrum is a scarce resource, but is relatively cheap to build the infrastructure which can also provide mobility and portability.

As described above, depending on the frequency range, the radio spectrum is divided into frequency bands and sub bands. The following picture tries to simplify the above classifications:

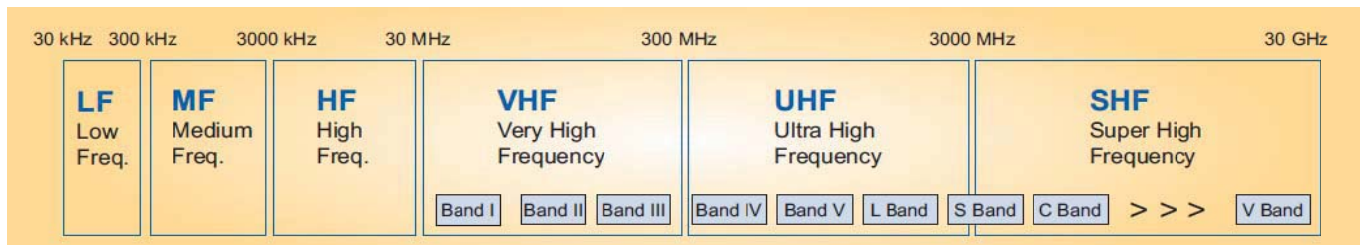

What is sweetspot in Radio Spectrum?

We should know that The Low Frequency (LF), Medium Frequency (MF) and High Frequency (HF) broadcasting bands (below 30 MHz) are still used in much the same way as they always have been since the birth of radio broadcasting over 80 years ago for Long Wave (LW), Medium Wave (MW) and Short Wave (SW) analogue broadcasting. Also in the HF band, a growing number of transmissions are being established in digital (DRM) format, primarily for international broadcasting. In the MF band, a limited range of frequencies are available for local analogue Medium Wave (MW) radio services. Please have a look at the following table that shows the general uses of different bands of the Radio spectrum.

Table of ITU Radio Bands				
Band Number	Symbols	Frequency Range	Wavelength Range	Typical sources
1	ELF	3 to 30 Hz	10,000 to 100,000 km	deeply-submerged submarine communication
2	SLF	30 to 300 Hz	1000 to 10,000 km	submarine communication, ac power grids
3	ULF	300 to 3000 Hz	100 to 1000 km	earthquakes, earth mode communication

-: About this document:-

4	VLF	3 to 30 kHz	10 to 100 km	near-surface submarine communication,
5	LF	30 to 300 kHz	1 to 10 km	AM broadcasting, aircraft beacons
6	MF	300 to 3000 kHz	100 to 1000 m	AM broadcasting, aircraft beacons, amateur two-way radio
7	HF	3 to 30 MHz	10 to 100 m	Skywave long range radio communication: shortwave broadcasting, military, maritime, diplomatic, amateur two-way radio
8	VHF	30 to 300 MHz	1 to 10 m	FM radio broadcast, television broadcast, PMR, DVB-T, MRI
9	UHF	300 to 3000 MHz	10 to 100 cm	PMR, television broadcast, microwave oven, GPS, mobile phone communication (GSM, UMTS, 3G, HSDPA), cordless phones (DECT), WLAN (Wi-Fi 802.11 b/g/n), Bluetooth
10	SHF	3 to 30 GHz	1 to 10 cm	DBS satellite television broadcasting, WLAN (Wi-Fi 802.11 a/n), microwave relays, WiMAX, radars
11	EHF	30 to 300 GHz	1 to 10 mm	microwave relays, intersatellite links, WiMAX, high resolution radar, directed-energy weapon (Active Denial System), Security screening (Millimeter wave scanner)
12	THF	300 to 3000 GHz	0.1 to 1 mm	Terahertz radiation, submillimeter radiation, low Infrared

The highlighted portion of the above spectrum table shows that the maximum number of the popular services such as **FM radio broadcast, television broadcast, PMR, DVB-T, MRI, PMR, television broadcast, microwave oven, GPS, mobile phone communication (GSM, UMTS, 3G, HSDPA), cordless phones (DECT), WLAN (Wi-Fi 802.11 b/g/n), Bluetooth** falls in the **VHF and UHF Band** of the Radio Spectrum. This is evident from the following simple picture taken from BBC:

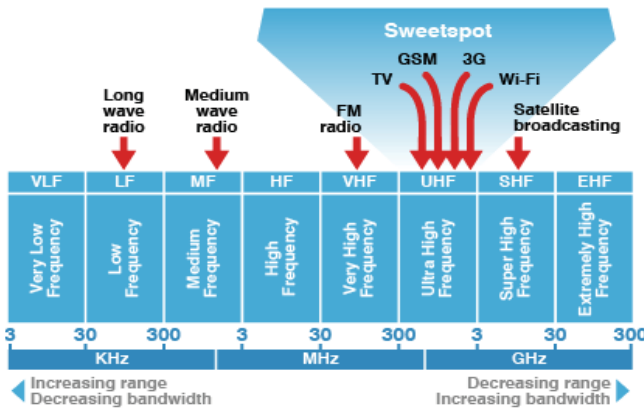

This portion is called "Sweetspot". So, please note that sweetspot is the part of the Radio Spectrum, where most modern communication technologies such as DAB Digital Radio, digital television, 3G mobile phones and WiFi wireless Internet access services operate. The sweetspot, in fact, is the upper part of the Very High Frequency (VHF) band and the whole of the Ultra High Frequency (UHF) band, incorporating frequencies from around 200 MHz to 3 GHz as illustrated in this image.

What are Bands and Channels?

In theory, different communication technologies could exist in any part of the radio spectrum, but we should note that, more information a signal is to carry, the more bandwidth it needs. In simple terms, **bandwidth is the range of frequencies that a signal occupies in the spectrum.** For example, an FM radio station might broadcast on a frequency of 92.9 MHz but requires a bandwidth of 0.3 MHz (300 kHz) – the spectrum between 92.8 and 93.0 MHz inclusive. Other stations cannot broadcast on these frequencies within the same area without causing or receiving interference. So for the purpose of the management of the services, the **spectrum bands are divided into channels.** The bandwidth of spectrum channels can vary band by band.

VHF Band II, the home of FM radio, for example, is **sliced up in 100 kHz-wide channels.** An FM station requires **300 kHz bandwidth,** therefore each FM radio station takes up three spectrum channels. In the case of television broadcasting, the agreed bandwidth of a channel in many parts of the world is 8 MHz in UHF Band IV/V. The bandwidth requirement of an analogue television programme channel is the same as the bandwidth of one spectrum television channel, i.e. 8 MHz

How Radio waves Propagate?

Transmission of Radio waves is called Radio Propagation. Akin to the light waves, radio waves are affected by the phenomena of *reflection, refraction, diffraction, absorption, polarization, scattering, daily changes of water vapor in the troposphere and ionization in the upper atmosphere.* ←

Once a radio signal has been transmitted, it has certain propagation characteristics associated with its frequency. **Propagation describes the behavior of a radio wave in spectrum.** In different bands, waves

-: About this document:-

have distinct abilities to hop, spread and penetrate. Certain waves can go through or bounce off walls or curve around corners better than others. The Very Low Frequency Radio waves propagate over the ground only. Medium Frequency propagates over the ground and in the sky at night. High Frequency hops between the ground and the sky.

- ✓ Please note that the Radio propagation is also **affected by factors that are determined by its path from point to point**. The path can be either direct line of sight path or an over-the-horizon path aided by **refraction in the ionosphere**. Some of these factors are sporadic-E, spread-F, solar flares, geomagnetic storms, ionospheric layer tilts, and solar proton events. Out of them, we need to discuss the structure of Ionosphere to understand the sporadic-E and Spread F before we move ahead.
- ✓ The lowest part of the Earth's atmosphere, the troposphere extends from the surface to about 10 km (6 miles). Above 10 km is the stratosphere, followed by the mesosphere.
- ✓ In the stratosphere incoming solar radiation creates the ozone layer. At heights of above 80 km (50 miles), in the thermosphere, the atmosphere is so thin that free electrons can exist for short periods of time before they are captured by a nearby positive ion.
- ✓ This portion of the atmosphere is ionized and **contains a plasma** which is referred to as the **ionosphere**.
- ✓ In a plasma, the negative free electrons and the positive ions are attracted to each other by the electromagnetic force, but they are too energetic to stay fixed together in an electrically neutral molecule.
- ✓ So, the ionosphere is a shell of electrons and electrically charged atoms and molecules that surrounds the Earth, stretching from a height of about 50 km to more than 1000 km.
- ✓ The **existence of Ionosphere is mainly due to ultraviolet radiation from the Sun**. The number of these free electrons in the ionosphere is sufficient to affect radio propagation.
- ✓ Since existence of Ionosphere is mainly due to ultraviolet radiation from the Sun, there is a diurnal (time of day) effect and a seasonal effect on the ionosphere.
- ✓ There is impact of the activity of the sunspot cycle, with more radiation occurring with more sunspots.
- ✓ The radiation received also varies with geographical location (polar, auroral zones, mid-latitudes, and equatorial regions).
- ✓ There are also mechanisms that disturb the ionosphere and decrease the ionization.
- ✓ There are disturbances such as solar flares and the associated release of charged particles into the solar wind which reaches the Earth and interacts with its geomagnetic field.

The Ionosphere is divided into some layers. The innermost layer, 60 km to 90 km above the surface of the Earth is called **D Layer**. It is followed by **E layer**, which is the middle layer, 90 km to 120 km above the surface of the Earth. The next outer layer is **Es layer** (sporadic E-layer), that is characterized by small, thin clouds of **intense ionization**, which can support reflection of radio waves, rarely up to 225 MHz This is called sporadic because the Sporadic-E events may last for just a few minutes to several hours. The outermost layer of the Ionosphere is **F layer or region**, also known as the **Appleton layer** that extends from about **200 km to more than 500 km** above the surface of Earth. It is the densest point of the ionosphere, which implies signals penetrating this layer will escape into space.

Most forms of sky wave propagation use the normal and cyclic ionization properties of the **ionosphere's F region** to refract radio signals back toward the Earth's surface, but the sporadic E propagation bounces signals off smaller "clouds" of unusually ionized atmospheric gas in the lower E region. This occasionally allows for long-distance communication at VHF frequencies.

The propagation of the Radio waves can be via surface (**ground wave**) or **direct line of sight** or via Ionosphere (**sky wave**).

Ground waves

Lower frequencies (between 30 and 3,000 kHz) have the property of following the curvature of the earth via ground wave propagation. This is possible because of the interaction of the radio waves with semi-conductive surface of the earth. The wave "clings" to the surface and thus follows the curvature of the earth.

Why only lower frequencies propagate via ground wave?

Since ground is not a perfect electrical conductor, ground waves are attenuated rapidly as they follow the earth's surface. This attenuation is **proportional to the frequency** and that is why this mode of propagation is useful for only LF and VLF frequencies.

Line of Sight

Line-of-sight is the direct propagation of radio waves between antennas that are visible to each other. This is one of the most common radio propagation modes at VHF and higher frequencies. Because radio signals can travel through many non-metallic objects, radio can be picked up through walls.

Skywave

Skywave propagation (skip) relies on **refraction (NOT Reflection)** of radio waves in the ionosphere.

F2-layer is the most important ionospheric layer for HF propagation, though F1, E, and D-layers also play some role. These layers are directly affected by the sun on a daily cycle, the seasons and the 11-year sunspot cycle determines the utility of these modes. During solar maxima, the whole HF range up to 30 MHz can be used and F2 propagation up to 50 MHz are observed frequently depending upon daily solar flux values. During solar minima, propagation of higher frequencies is generally worse. (wikipedia)

How Radio sets work?

The real nice thing about the radio waves is that they will make the electrons in a piece of copper wire move; this means they are capable of generating the electric currents in the wire. It works both the ways, alternating currents in a copper wire generate electromagnetic waves, and the electronic waves generate the alternating currents. The electric currents at "Radio frequencies" (rf) are used by the radio and television transmitters and receivers.

Each Radio system contains a transmitter that consists of a source of electrical energy, producing alternating current of a desired frequency of oscillation. The transmitter contains a system to modulate (change) some property of the energy produced to impress a signal on it. This modulation might be as simple as turning the energy on and off, or altering more subtle properties such as amplitude, frequency, phase, or combinations of these properties. The transmitter sends the modulated electrical energy to a tuned resonant antenna; this structure converts the rapidly changing alternating current into an electromagnetic wave that can move through free space (sometimes with a particular polarization). When transmitted, the transceiver "modulates" the RF with an alternating current generated by voice in a microphone. The Modulating frequency is called AF or Audio Frequency. Someone listening uses a receiver which can demodulate the Radio signal. The Receiver removes the RF to leave the AF and thus audio signal is fed to a loudspeaker.

The electromagnetic wave is intercepted by a tuned receiving antenna; this structure captures some of the energy of the wave and returns it to the form of oscillating electrical currents. At the receiver, these currents are demodulated, which is conversion to a usable signal form by a detector sub-system. The receiver is "tuned" to respond preferentially to the desired signals, and reject undesired signals.

Why the frequency of FM Radio generally ranges between 90 and 110 MHz?

FM stands for Frequency Modulation. The frequencies between 80MHz to 110MHz, generally used to broadcast FM across the world, all fall in the **VHF frequency range** of 30Mhz to 300Mz. Since, FM has almost become an international standard for local broadcasts within city boundaries, the frequency range being used across the globe have been in the **88 to 106 MHz range** only. Please note that first FM transmission took place in the US in the 1940s in the frequency band 42 to 50MHz. Later in 1945, the Federal Communications Commission allocated bands from 88 to 106MHz for FM broadcasting, citing reasons for its non-interference with other radio bands in and around a city.

-: About this document:-

All radio receptions except FM band are affected when cable TV is switched on. Why?

This is a very simple question related to fundamentals of electromagnetic waves. Whenever we switch on an electrical equipment, there are electrical currents in different parts of the circuit, which are associated with a magnetic field in its neighbourhood. The strength of this magnetic field reduces as the distance increases. If the current is alternating current (AC), equipment would work as a source of electromagnetic waves. These waves are called EM noise for other equipments. The AC current generates EM waves at such frequencies that can be detected by a radio receiver tuned to an amplitude-modulated band. In the neighbourhood of a noise producing equipment like a TV, the signal received by the antenna of the radio receiver is altered by the picked up EM waves; and it would be taken by the receiver as the total signal to process.

Why transistor radio gives a clear and loud reception when the antenna is held or touched by hand?

We all know that the antenna of a transistor radio is the first stage which collects the radio signal of all frequencies. The clarity and loudness of the audio depends, among many other factors, on the strength of the signal received by the antenna. If we increase the collection area, the signal received is enhanced. A long stretched conducting wire or a spread out conducting object work as signal enhancer when connected to the antenna. Human body has also some conductivity and when we touch the antenna of an operating radio set, we increase the effective signal collection area and thereby the signal strength gets improved and the loudness increases.

Microwaves

This part of the Radio Spectrum has wavelengths such short that they are easily absorbed by water and this is the core principle that they are used in microwave ovens. When we keep our food in microwave, the energy of the microwaves is converted into heat and makes the water molecules vibrate faster.

By "microwaves" we mean the range of radio frequencies between about 1 GHz (one gigahertz, or one billion oscillations per second) and about 300 GHz. Although there is no formal definition of the frequency range for "microwaves", some text books will define all frequencies above 300 MHz as microwaves.

The term "microwaves" seems to have first appeared in writing in a 1932 paper by Nello Carrara in the first issue of *Alta Frequenza*. The Italian word is *microonde*. The term gained acceptance during the second world war to describe wavelengths less than about 30 cm. These waves were much shorter than those normally used for communications (at that time), but were being used in RADAR.

A 30 centimeter wavelength is equivalent to 1 GHz (to convert from frequency to wavelength, just divide the speed of light 300,000,000 meters per second by the frequency in cycles per second to get meters of wavelength).

Why Microwaves are considered better than Radio waves for safer communication?

Microwaves are easier to control (than longer wavelengths) because small antennas could detect the waves very well. One advantage of such control is that the energy could be easily confined to a tight beam (narrow beam width). This beam could be focused on another antenna dozens of miles away, making it very difficult for someone to intercept the conversation. Another characteristic is that because of their high frequency, greater amounts of information could be put on them (increased modulation bandwidth). Both of these advantages (narrow beam width and modulation bandwidth) make microwaves very useful for RADAR as well as communications.

Eventually, these qualities led to the use of microwaves by the telephone companies. They placed towers every 30 to 60 miles each with antennas, receivers and transmitters. These would relay hundreds or even thousands of voice conversations across the country. The ability to modulate with a wide bandwidth permitted so many conversations on just one signal, and the reduction in beam width made this reasonably secure.

Note: Please note that above 100 MHz, the waves travel in straight lines and can therefore be narrowly focused. Concentrating all the energy into a small beam using a parabolic antenna (like the satellite TV dish) gives a much higher signal to noise ratio, but the transmitting and receiving antennas must be accurately aligned with each other.

Use of Microwaves:

Please note that microwave transmission is weather and frequency dependent. Microwave communication was widely used for long distance telephone communication, cellular telephones, television distribution and other uses that a severe shortage of spectrum has developed.

-: About this document:-

- Microwave is relatively inexpensive in comparison to fiber optics system. For example, putting up two simple towers and antennas on each one may be cheaper than burying 50 km of fiber through a congested area or up lower a mountain.
- Microwave systems permit data transmission rates of about 16 Giga (1 giga = 10⁹) bits per second. At such high frequencies, microwave systems can carry 250,000 voice channels at the same time.
- This is the core principle that they are mostly used to link big metropolitan cities where have heavy telephone traffic between them.

But, there is a big **limitation**. Since **microwaves travel in a straight line**, if the towers are too far apart, the earth will get in the way. Consequently, repeaters are needed periodically. **The higher the towers are, the further apart they can be.** The distance between repeaters goes up very roughly with the square root of the tower height. For 100 meter high towers, repeaters can be spaced 80 km apart

Today, **Microwaves are used in the following:**

1. **Wireless LAN:** Wireless LAN protocols, such as **Bluetooth**. Please note that Bluetooth uses microwaves in the **2.4 GHz ISM band** ((short wavelength radio transmissions in the ISM band from 2400-2480 MHz).
2. **Wireless Internet Access :** Licensed long-range (up to about 25 km) Wireless Internet Access services use microwaves in the **3.5-4.0 GHz** range.
3. **MAN:** Metropolitan area network (MAN) protocols, such as **WiMAX** (Worldwide Interoperability for Microwave Access) are based on standards such as IEEE 802.16, designed to operate between **2 to 11 GHz**. Commercial implementations are in the 2.3 GHz, 2.5 GHz, 3.5 GHz and 5.8 GHz ranges.
4. **MBWA:** Mobile Broadband Wireless Access (MBWA) protocols based on standards specifications such as IEEE 802.20 or ATIS/ANSI HC-SDMA (such as iBurst) operate between **1.6 and 2.3 GHz** to give mobility and in-building penetration characteristics similar to mobile phones.
5. **GSM:** GSM (Global System for Mobile Communications) use the low-microwave/high-UHF frequencies around **1.8 and 1.9 GHz** in the Americas and elsewhere, respectively.
6. **DVB-SH and S-DMB:** DVB-SH (Digital Video Broadcasting - Satellite services to Handhelds) and S-DMB (Satellite-Digital Multimedia Broadcasting) use **1.452 to 1.492 GHz**, while proprietary/incompatible satellite radio in the U.S. uses around 2.3 GHz for DARS.
7. **Microwave Radio:** Microwave radio is used in broadcasting and telecommunication transmissions because, due to their short wavelength, highly directional antennas are smaller and therefore more practical than they would be at longer wavelengths (lower frequencies). There is also more bandwidth in the microwave spectrum than in the rest of the radio spectrum; the usable bandwidth below 300 MHz is less than 300 MHz while many GHz can be used above 300 MHz.
8. **Satellite Communications:** Most satellite communications systems operate in the **C, X, Ka, or Ku bands of the microwave spectrum**. These frequencies allow large bandwidth while avoiding the crowded UHF frequencies and staying below the atmospheric absorption of EHF frequencies. Satellite TV either operates in the C band for the traditional large dish fixed satellite service or Ku band for direct-broadcast satellite. **Military communications run primarily over X or Ku-band links**, with Ka band being used for Milstar.
9. **RADAR:** Radar uses **microwave radiation** to detect the range, speed, and other characteristics of remote objects.
10. **Radio Astronomy:** Most radio astronomy uses microwaves. Usually the naturally-occurring microwave radiation is observed, but active radar experiments have also been done with objects in the solar system, such as determining the distance to the Moon or mapping the invisible surface of Venus through cloud cover.
11. **GNSS and GPS:** Global Navigation Satellite Systems (GNSS) including the Chinese Beidou, the American Global Positioning System (GPS) and the Russian GLONASS broadcast navigational signals in various bands between about **1.2 GHz and 1.6 GHz**.
12. **Microwave Ovens:** Microwave oven passes **(non-ionizing)** microwave radiation (at a frequency near **2.45 GHz**) through food, causing dielectric heating by absorption of energy in the water, fats, and sugar contained in the food. Water in the liquid state possesses many molecular interactions which broaden the absorption peak. In the vapor phase, isolated water molecules absorb at around 22 GHz, almost ten

times the frequency of the microwave oven. Microwave heating is used in industrial processes for drying and curing products.

13. **PECVD:** PECVD refers to plasma-enhanced chemical vapor deposition and many semiconductor processing techniques use microwaves to generate plasma for such purposes.
14. **Transmission of power:** Microwaves can be used to transmit power over long distances, and post-World War II research was done to examine possibilities. ←
15. **Weapons:** Less-than-lethal weaponry exists that uses millimeter waves to heat a thin layer of human skin to an intolerable temperature so as to make the targeted person move away.
16. **Spectroscopy:** Microwave radiation is used in electron paramagnetic resonance (EPR or ESR) spectroscopy, typically in the X-band region in conjunction typically with magnetic fields of 0.3 T. This technique provides information on unpaired electrons in chemical systems, such as free radicals or transition metal ions such as Cu(II). The microwave radiation can also be combined with electrochemistry as in microwave enhanced electrochemistry.
17. **MASER:** MASER refers to **Microwave Amplification by Stimulated Emission of Radiation**, which is a device that produces coherent radio and microwaves through amplification by stimulated emission. Masers serve as high precision frequency references. These "atomic frequency standards" are one form of atomic clock. They are also used as electronic amplifiers in radio telescopes. Masers are being developed as directed-energy weapons. Most important type of maser is the hydrogen maser which is currently used as an atomic frequency standard.

Infrared Waves

These radio/light waves have very short wavelengths, which are longer than the visible light at 0.74 micrometers, and extending conventionally to 300 micrometers.

- These wavelengths correspond to a frequency range of approximately **1 to 400 THz.**
- The infrared portion of the electromagnetic spectrum is usually divided into three regions; the near-, mid- and far- infrared, named for their relation to the visible spectrum. The higher energy **near-IR,** approximately **14000–4000 cm⁻¹** (0.8–2.5 μm wavelength) can excite overtone or harmonic vibrations. The **mid-infrared,** approximately **4000–400 cm⁻¹** (2.5–25 μm) may be used to study the fundamental vibrations and associated rotational-vibrational structure. The **far-infrared,** approximately **400–10 cm⁻¹** (25–1000 μm), lying adjacent to the microwave region, has low energy and may be used for rotational spectroscopy

There are three bands of Infrared radiation as stipulated by the International Commission on Illumination (CIE) as follows:

1. IR-A: 700 nm–1400 nm (0.7 μm – 1.4 μm, 215 THz - 430 THz)
2. IR-B: 1400 nm–3000 nm (1.4 μm – 3 μm, 100 THz - 215 THz)
3. IR-C: 3000 nm–1 mm (3 μm – 1000 μm, 300 GHz - 100 THz)

However, the ISO 20473 standard divides the Infrared as follows:

Designation	Abbreviation	Wavelength
Near Infrared	NIR	0.78 - 3 μm
Mid Infrared	MIR	3 - 50 μm
Far Infrared	FIR	50 - 1000 μm

The Infrared radiation can also be divided into 7 bands for the purpose of Telecommunication as follows:

Band	Descriptor	Wavelength range
O band	Original	1260–1360 nm
E band	Extended	1360–1460 nm
S band	Short wavelength	1460–1530 nm
C band	Conventional	1530–1565 nm
L band	Long wavelength	1565–1625 nm

-: About this document:-

U band	Ultralong wavelength	1625–1675 nm
--------	----------------------	--------------

Applications of Infrared:

- Active-infrared night vision :** In this, the camera illuminates the scene at infrared wavelengths invisible to the human eye. Infrared is used in night vision equipment when there is insufficient visible light to see.

How the Night vision devices work?

Night vision goggles work on the principle of infrared radiation, which radiates from any object in relation to its temperature. A hotter body radiates more infrared radiation. A night vision goggle receives this radiation from the surroundings and makes out places which are comparatively warmer (usually warm-blooded animals like human beings) helping the user to see in the dark or through a fog. Please note that night vision devices operate through a process involving the conversion of ambient light photons into electrons which are then amplified by a chemical and electrical process and then converted back into visible light.

What is difference between night vision and thermal imaging?

Both vision and thermal imaging work on the basis of properties of the infrared radiation but the working is different. Thermal imaging creates images based on differences in surface temperature by detecting infrared radiation (heat) that emanates from objects and their surrounding environment. Thermographic cameras detect radiation in the infrared range of the electromagnetic spectrum (roughly 900–14,000 nanometers or 0.9–14 μm) and produce images of that radiation.

- Thermography & Pyrometry:** Infrared radiation can be used to remotely determine the temperature of objects. If they are used in case of very hot objects, it is called thermography, while if used in visible, then it is termed pyrometry. Thermography is mainly used in military and industrial applications but the technology is reaching the public in the form of infrared cameras on cars.
- Hyperspectral imaging:** Hyperspectral imaging collects and processes information from across the electromagnetic spectrum. Much as the human eye sees visible light in three bands (red, green, and blue), spectral imaging divides the spectrum into many more bands. Hyperspectral imaging is gaining importance in the applied spectroscopy. Its applications include biological, mineralogical, defence, and industrial measurements.
- Infrared tracking:** Infrared tracking, also known as infrared homing, refers to a passive missile guidance system which uses the emission from a target of electromagnetic radiation in the infrared part of the spectrum to track it.

What are Heat seekers?

Missiles which use infrared seeking are often referred to as "heat-seekers", since infrared (IR) is just below the visible spectrum of light in frequency and is radiated strongly by hot bodies. Many objects such as people, vehicle engines, and aircraft generate and retain heat, and as such, are especially visible in the infrared wavelengths of light compared to objects in the background

- Communications:** IR data transmission is used in short-range communication among computer peripherals and personal digital assistants. The standards to use these devices is published by IrDA (Infrared Data Association).

How Remote Controls work?

The devices such as Remote Controls use infrared light-emitting diodes (LEDs) to emit infrared radiation which is focused by a plastic lens into a narrow beam. The beam is modulated, i.e. switched on and off, to encode the data. The receiver uses a silicon photodiode to convert the infrared radiation to an electric current. It responds only to the rapidly pulsing signal created by the transmitter, and filters out slowly changing infrared radiation from ambient light. Infrared communications are useful for indoor use in areas of high population density. IR does not penetrate walls and so does not interfere with other devices in adjoining rooms. Infrared is the most common way for remote controls to command appliances. Infrared remote control protocols like RC-5, SIRC, are used to communicate with infrared.

- Spectroscopy:** Infrared vibrational spectroscopy is a technique which can be used to identify molecules by analysis of their constituent bonds.
- Meteorology:** The Weather satellites equipped with scanning radiometers produce thermal or infrared images which can then enable a trained analyst to determine cloud heights and types, to calculate land and surface water temperatures, and to locate ocean surface features. The scanning is typically in the

-: About this document:-

range 10.3-12.5 μm (IR4 and IR5 channels). Satellites use sensors whose working principle is based on photoelectric effect, converting radiation reaching the sensor into electric charge, which can then be easily measured and processed.

Essentially, the energy detected over a given spectral band, whether it is in the Thermal / Infrared (or even microwave) band, is converted to an array of digits corresponding to the energy range and radioed to ground stations. After receiving it, those digital values corresponding to the measured energy range (known as grey levels) are finally printed on a computer screen as a picture or as a conventional photograph. The main advantage of infrared is that **images can be produced at night**, allowing a continuous sequence of weather to be studied.

8. **Climatology:** Infrared pictures can depict **ocean eddies** or vortices and **map currents** such as the Gulf Stream, even **El Niño phenomena** can be spotted. Infrared can detect trends in the energy exchange between the earth and the atmosphere. These trends provide information on long term changes in the Earth's climate. It is one of the primary parameters studied in research into global warming together with solar radiation.
9. **Astronomy:** Astronomers observe objects in the infrared portion of the electromagnetic spectrum using optical components, including mirrors, lenses and solid state digital detectors. For this reason it is classified as part of optical astronomy. To form an image, the components of an infrared telescope need to be carefully shielded from heat sources, and the detectors are chilled using liquid helium. However, **sensitivity of Earth-based infrared telescopes is significantly limited by water vapor in the atmosphere**, which absorbs a portion of the infrared radiation arriving from space outside of selected atmospheric windows. It can be partially alleviated by placing the telescope observatory at a high altitude, or by carrying the telescope aloft with a balloon or an aircraft. Space telescopes do not suffer from this handicap, and so **outer space** is considered the ideal location **for infrared astronomy**. The **Spitzer Space Telescope** is a dedicated infrared space observatory currently in orbit around the Sun.
10. **History:** Use of infrared are made by historians on various types of objects, especially very old written documents such as the Dead Sea Scrolls, the Roman works in the Villa of the Papyri, and the Silk Road texts found in the Dunhuang Caves. Carbon black used in ink can show up extremely well.
11. **Biology:** The pit viper has a pair of infrared sensory pits on its head, however not much details are known about its functionality. The other organisms that have thermo receptive organs are pythons, some boas, the Common Vampire Bat, some beetles, some darkly pigmented butterflies.
12. **Photobiomodulation:** It's a chemotherapy induced oral ulceration as well as wound healing that uses near infrared light.

MOBILE TELEPHONY

The name Cellular Phone is derived from the partition of a Geographic Region into smaller areas which are called "Cells". The Voice and data exchanged between the Mobile terminal and phone / internet is transmitted via the Mobile Network which consists of Cellular Operator's radio access network and core network.

One of the most popular and common application of the radio waves is in the area of mobile telephony. Today, the mobile telephony uses the cellular radio service but in older times the mobile telephone service consisted of bulky mobile telephone radio units. These two way radio units were able to communicate with each other via a single antenna in a particular area. At that time, these radio signals used to interfere with each other and the limit was thus very limited. The service was unreliable and costly.

Brief History (from wikipedia)

- ✓ First mobile telephone call made from a car occurred in St. Louis, Missouri, USA on June 17, 1946, using the Bell System's Mobile Telephone Service.
- ✓ In 1956, the world's first partly automatic car phone system, Mobile System A (MTA), was launched in Sweden.
- ✓ Martin Cooper, a Motorola researcher and executive was the inventor of the first practical mobile phone for handheld use; Cooper made the first call on a handheld mobile phone on April 3, 1973 to his rival, Dr. Joel S. Engel of Bell Labs.

-: About this document:-

- ✓ The first commercially automated cellular network (the 1G) was launched in Japan by NTT in 1979, initially in the metropolitan area of Tokyo. Within five years, the NTT network had been expanded to cover the whole population of Japan and became the first nationwide 1G network. In 1981, this was followed by the simultaneous launch of the Nordic Mobile Telephone (NMT) system in Denmark, Finland, Norway and Sweden. NMT was the first mobile phone network featuring international roaming.
- ✓ The first 1G network launched in the USA was Chicago-based Ameritech in 1983 using the Motorola DynaTAC mobile phone. Several countries then followed in the early-to-mid 1980s including the UK, Mexico and Canada.
- ✓ The first "modern" network technology on digital 2G (second generation) cellular technology was launched by Radiolinja (now part of Elisa Group) in 1991 in Finland on the GSM standard, which also marked the introduction of competition in mobile telecoms when Radiolinja challenged incumbent Telecom Finland (now part of TeliaSonera) who ran a 1G NMT network.
- ✓ In 2001, the first commercial launch of 3G (Third Generation) was again in Japan by NTT DoCoMo on the WCDMA standard.
- ✓ One of the newest 3G technologies to be implemented is High-Speed Downlink Packet Access (HSDPA). It is an enhanced 3G (third generation) mobile telephony communications protocol in the high-speed packet access (HSPA) family, also coined 3.5G, 3G+ or turbo 3G, which allows networks based on Universal Mobile Telecommunications System (UMTS) to have higher data transfer speeds and capacity.

Development of 1G, 2G and 3G

1G:

The development of 1G mobile phones took place in late 1970s. The 1G mobile devices sent only the "analogue voice information" via amplitude modulation (AM), which varies the amplitude of the carrier signal, and frequency modulation (FM), which changes the Frequency of the carrier signal. In electronics, the analog signal devices were followed by Analog to Digital convertors.

The most important 1G systems were

1. Advanced Mobile Phone System (AMPS)
2. Nordic Mobile Telephone (NMT)
3. Total Access Telephone System (TACS).

The devices of the 1G included the Cordless Phone, Paging Systems, Private Mobile Radio, Some primitive mobile systems as mentioned above.

2G

The 2G phase began in the 1990s and much of this technology is still in use. The 2G cell phone features digital voice encoding. Examples include CDMA and GSM. Since its inception, 2G technologies have steadily improved, with increased bandwidth, packet routing, and the introduction of multimedia.

☞ GSM is most popular standard for mobile telephony systems spread in more than 200 countries / territories. GSM is a cellular network, which means that mobile phones connect to it by searching for cells in the immediate vicinity.

The worldwide presence of GSM means that subscribers can use their phones throughout the world, enabled by international roaming arrangements between mobile network operators.

☞ GSM networks operate in a number of different carrier frequency ranges and most 2G GSM networks operate in the 900 MHz or 1800 MHz bands.

GSM provides the voice and limited data services and uses the digital modulation for improved audio quality. So this was the beginning of the SMS. The rate was 10 Kbps/user. Some standards used in 2G are as follows:

1. Paging Systems

-: About this document:-

2. Advanced Cordless Phones such as DECT and PACS
3. WLL (Wireless in Local Loop)
4. Private Mobile Radio such as TETRA
5. Cellular Systems such as GSM
6. Mobile Satellite systems such as IRIDIUM, GLOBALSTAR etc.

The development of the 2G was a response to the demand of data transmission.

2.5 G:

The 2G was succeeded with **GPRS** i.e. **General Packet Radio Service**. This is called **2.5G**. This enhanced the data transmission capacity of the GSM and added the packet switched capabilities to the existing mobile telephony. So now the systems were able to send emails and Graphics rich data as a higher speed. 2.5 G or GPRS set the preparatory stage for the 3G

☞ Applications in 2.5 G are : Digital voice and limited data

3G:

3G adds multimedia facility to the 2G phones by allowing them **video, audio, graphics applications**. **The idea behind 3G is to go for a single standard worldwide.**

The 3G includes the capabilities and features such as **enhanced multimedia** (voice, data, video, and remote control), Usability on all popular modes (cellular telephone, e-mail, paging, fax, videoconferencing, and Web browsing), Broad bandwidth and high speed (upwards of 2 Mbps), Roaming capability throughout Europe, Japan, and North America

☞ India entered the 3G arena with the launch of 3G enabled Mobile and Data services by BSNL in 2008.

☞ MTNL launched 3G in Delhi and Mumbai later.

☞ Nationwide auction of 3G wireless spectrum was announced in April 2010.

☞ The first Private-sector service provider that launched 3G services is Tata Docomo, on November 5 2010.

☞ Second is by Airtel in the middle of the same month. Other providers like Vodafone, Idea and Aircel are expected to launch 3G services by January 2011.

GSM Standards

During the early 1980s, analog cellular telephone systems were experiencing rapid growth in Europe. Each country developed its own system; which was incompatible with others in equipment and operation. This was an undesirable situation, because not only was the mobile equipment limited to operation within national boundaries but there was also a very limited market for each type of equipment, so economies of scale and the subsequent savings could not be realized.

It was realized by the European countries and they clubbed together to make a group called *Groupe Spécial Mobile* (GSM) in 1982 to study and develop a pan-European mobile system. Thus, the GSM emerged as 2G standard to cater voice services and data delivery. **The Commercial service in GSM started in 1991 and now we see the GSM networks everywhere.** The most basic service provided by GSM is telephony but also a variety of data services is offered. Since GSM is a digital network, a modem is not required between the user and GSM network.

Instead of using analog service, **GSM was developed as a digital system** using TDMA (Time division multiple access) technology. Using TDMA, a narrow band that is 30 kHz wide and 6.7 milliseconds long is split time-wise into three time slots. Each conversation gets the radio for one-third of the time. This is possible because voice data that has been converted to digital information is compressed so that it takes up significantly less transmission space. Therefore, TDMA has three times the capacity of an analog system using the same number of channels.

GSM systems provide a number of useful features:

- ☞ Uses encryption to make phone calls more secure
- ☞ Data networking

-: About this document:-

- 👉 Group III facsimile services
- 👉 Short Message Service (SMS) for text messages and paging
- 👉 Call forwarding
- 👉 Caller ID
- 👉 Call waiting
- 👉 Multi-party conferencing

Please note that GSM operates in the 900 MHz band (890 MHz - 960 MHz) in Europe and Asia and in the 1900 MHz (sometimes referred to as 1.9 GHz) band in the United States. It is used in digital cellular and PCS-based systems.

Architecture of GSM

In a fixed telephone network, providing and managing connections is a relatively easy process, because telephones are connected by wires to the network and their location is permanent from the networks' point of view. In a mobile network, however, the establishment of a call is a far more complex task, as the wireless (radio) connection enables the users to move at their own free will providing they stay within the network's service area. In practice, the network has to find solutions to three problems before it can even set up a call:

- 👉 Where is the subscriber
- 👉 Who is the subscriber
- 👉 What does the subscriber want

One of the main purposes behind the GSM specifications is to define several open interfaces, which then limit certain parts of the GSM system. The GSM specifications define two truly open interfaces within the GSM network. The first one is between the Mobile Station (MS) and the Base Station (BS). This open-air interface is appropriately named the "air interface". The second interface is located between the Mobile services Switching Centre, MSC, (which is the switching exchange in GSM) and the Base Station Controller (BSC). This interface is called the "A-interface".

In a GSM network, this decentralized intelligence is implemented by dividing the whole network into three separate subsystems:

1. Network Switching Subsystem (NSS)
2. Base Station Subsystem (BSS)
3. Network Management Subsystem (NMS)

The actual network needed for establishing calls is composed of the NSS and the BSS. The BSS is responsible for radio path control and every call is connected through the BSS. The NSS takes care of call control functions. Calls are always connected by and through the NSS.

Mobile Station

The mobile station (MS) consists of the mobile equipment (the terminal) and a smart card called the Subscriber Identity Module (SIM). The mobile equipment is uniquely identified by the International Mobile Equipment Identity (IMEI). The SIM card contains the identification numbers of the user (International Mobile Subscriber Identity (IMSI)) and a list of available networks. The SIM card also contains tools needed for authentication and ciphering. Depending on the type of the card, there is also storage space for messages, such as phone numbers.

The SIM card may be protected against unauthorized use by a password or personal identity number.

Base Station Subsystem

The Base Station Subsystem is composed of two parts, the Base Transceiver Station (BTS) and the Base Station Controller (DSC). These communicate across a standardized interface, allowing (as in the rest of the system) operation between components made by different suppliers.

The Base Transceiver Station houses the radio transceivers that define a cell and handles the radio-link protocols with the Mobile Station.

Network Switching Subsystem (NSS)

-: About this document:-

The central component of the Network Subsystem is the Mobile services Switching Center (MSC). It acts like a normal switching node of the PSTN or ISDN, and in addition provides all the functionality needed to handle a mobile subscriber, such as registration, authentication, location updating, handovers, and call routing to a roaming subscriber.

Does GSM allow signals when we travel in aeroplane?

We should not that territory covered with GSM network is divided into hexagonal cells. The covering diameter of each hexagonal cell may be from 400 m up to 50 km, which consists of base station that provides communication-receive and transmission, and antennae. All GSM cellular communication telephone cells are performed via these antennae and stations, which are regulated by switching centre. Switching centre provides communication between city telephone network, base stations and other cellular communication operators. Every time you switch on your cell phone, the communication is performed with the nearest base station. Hence it is also possible to receive signals on cell phone while travelling in an aeroplane, **provided the base station range allows.**

Cell phone use during flights is still banned by regulations because it disrupts cell service on the ground and have the potential to interfere with an airplane's navigation and communication instruments.

Code Division Multiple Access (CDMA)

CDMA (Code Division Multiple Access) is a digital cellular technology that uses spread-spectrum techniques. Unlike competing systems, such as GSM, that use TDMA, CDMA does not assign a specific frequency to each user. Instead, every channel uses the full available spectrum. Individual conversations are encoded with a pseudo-random digital sequence. CDMA consistently provides better capacity for voice and data communication than other commercial mobile technologies, allowing more subscribers to connect at any given time, and it is the common platform on which 3G technologies are built.

CDMA is a military technology first used during World War II by the British and their allies to foil German attempts at jamming transmissions.

Advantages and Disadvantages of CDMA

The CDMA Phones don't have SIM cards. The CDMA phones have phone numbers programmed in the handset just as numbers are programmed in SIM cards by the operator. The latest phones have both options. Since all CDMA phones are network locked, there is no necessity for the SIM card provision. As GSM phones are compatible with any operator, who provides the SIM card which enables connectivity to the network. This makes the phone independent of the operator.

A major difference between the CDMA and GSM networks is the handset. In CDMA, the handsets are provided by the operator and they work only on one network unlike in GSM systems.

One of the major advantages of CDMA is "Soft Handoff". A handoff occurs in any cellular network where a call switches from one -cell site to another as a person travels: In other technologies this handoff occurs when the network informs the phone of the new channel to which it must switch. The phone then stops receiving and transmitting on the old channel, and it commences transmitting and receiving on the new channel. This is known as a "Hard Handoff". In CDMA, however, every site is on the same frequency. In order to begin listening to a new site, the phone only needs to change the pseudo-random sequence it uses to decode the desired data from the jumble of bits sent for everyone else. While a call is in progress the network chooses two or more alternate sites that it feels are handoff candidates. It simultaneously broadcasts a copy of the call on each of these sites. The phone can then pick and choose between the different sources for the call, and move between them whenever it feels like it. It can even combine the data received from two or more different sites to ease the transition from one to the other.

This puts the phone in almost complete control of the handoff process. Such an arrangement should ensure that there is always a new site ready to take over the call at a moment's notice.

CDMA has a very high "spectral efficiency". It can accommodate more users per MHz of bandwidth than any other technology.

Disadvantages:

-: About this document:-

A major problem facing CDMA systems is "channel pollution". This occurs when signals from too many base stations are present at the subscriber's phone, but none are dominant. When this situation occurs the audio quality degrades rapidly, even when the signal seems otherwise very strong.

Bluetooth

Bluetooth is a low cost, low power, **radio interface** standard for wireless communication over short distances. It's an **open standard for allowing intelligent devices to communicate with each other**. This allows any sort of electronic equipment (from computers and cell phones to keyboards and headphones) to make its own connections, without wires, cables or any direct action from a user. It could allow for replacing many propriety cables that connect one device to another with one universal radio link.

Please note that Bluetooth was originally conceived as a cable replacement technology providing short-Range Wireless Solutions with open specifications, voice and data capability.

Why Blue, why not any other color?

Please note that Bluetooth is the anglicized form of the Danish word *Bletand* — Ble meaning blue — the victory title given to the 10th century King Harald Gormsson. Harald was born in circa 935 and ruled as King of Denmark around 958 and as King of Norway around 970. Bluetooth technology was invented in 1994 by Swedish company Ericsson, which found it appropriate to name it after the Scandinavian king who had united several Danish tribes and parts of Norway into a single kingdom. The implication is that a Bluetooth does the work of uniting different communication protocols into one universal standard.

Why Bluetooth?

Whenever two devices need to communicate with each other, they have to agree on a number of points before the communication can begin. The first point of agreement is physical: Will they talk over wires, or through some form of wireless signals? If they use wires, how many are required? Once the physical attributes are decided, there are other questions such as - How much data will be sent at a time? All of the devices in an electronic discussion need to know what the bits mean and whether the message they receive is the same message that was sent. This means developing a set of commands and responses known as a protocol. But Bluetooth offers an obviation to this rule. So, Bluetooth is essentially an OPEN networking standard that works at two levels viz. Physical and Protocol.

Bluetooth networking transmits data via low-power radio waves. It communicates on a frequency of 2.45 gigahertz (actually between 2.402 GHz and 2.480 GHz, to be exact). This frequency band has been set aside by international agreement for the use of industrial, scientific and medical devices (ISM).

Does Bluetooth interfere with other systems?

No. Bluetooth devices avoid interfering with other systems is by sending out very weak signals of about 1 milliwatt. By comparison, the most powerful cell phones can transmit a signal of 3 watts. The low power limits the range of a Bluetooth device to about 10 meters (32 feet), cutting the chances of interference between computer system and portable telephone or television. Even with the low power, Bluetooth doesn't require line of sight between communicating devices. Thus, the walls in our houses won't stop a Bluetooth signal, making the standard useful for controlling several devices in different rooms.

What is spread-spectrum frequency hopping?

Bluetooth can connect up to eight devices simultaneously, with all of those devices in the same 10-meter (32-foot) radius, but still these devices don't interfere with each other. For this, Bluetooth uses a technique called spread-spectrum frequency hopping that makes it rare for more than one device to be transmitting on the same frequency at the same time. In spread-spectrum frequency hopping, a device will use 79 individual, randomly chosen frequencies within a designated range, changing from one to another on a regular basis. In the case of Bluetooth, the transmitters change frequencies 1,600 times every second, meaning that more devices can make full use of a limited slice of the radio spectrum. Since every Bluetooth transmitter uses spread-spectrum transmitting automatically, it's unlikely that two transmitters will be on the same frequency at the same time. This same technique minimizes the risk that portable phones or baby monitors will disrupt Bluetooth devices, since any interference on a particular frequency will last only a tiny fraction of a second.

-: About this document:-

What is Bluetooth Piconet?

A piconet is a collection of devices connected via Bluetooth technology in an ad hoc fashion. A piconet starts with two connected devices, such as a portable PC and cellular phone, and may grow to eight connected devices. All Bluetooth devices are peer units and have identical implementations. However, when establishing a piconet, one unit will act as a master and the other as slave for the duration of the piconet connection.

When Bluetooth-capable devices come within range of one another, an electronic conversation takes place to determine whether they have data to share or whether one needs to control the other. The user doesn't have to press a button or give a command -- the electronic conversation happens automatically. Once the conversation has occurred, the devices -- whether they're part of a computer system or a stereo -- form a network. Thus, Bluetooth systems create a personal-area network (PAN). Once a piconet is established, the members randomly hop frequencies in unison so they stay in touch with one another and avoid other piconets that may be operating in the same room.

We take an example of a typical modern living room with typical modern devices inside. There's an entertainment system with a stereo, a DVD player, a satellite TV receiver and a television; there's also a cordless telephone and a personal computer. Each of these systems uses Bluetooth, and each forms its own piconet to talk between the main unit and peripheral.

The cordless telephone has one Bluetooth transmitter in the base and another in the handset. The manufacturer has programmed each unit with an address that falls into a range of addresses it has established for a particular type of device. When the base is first turned on, it sends radio signals asking for a response from any units with an address in a particular range. Since the handset has an address in the range, it responds, and a tiny network is formed. Now, even if one of these devices should receive a signal from another system, it will ignore it since it's not from within the network. The computer and entertainment system go through similar routines, establishing networks among addresses in ranges established by manufacturers. Once the networks are established, the systems begin talking among themselves. Each piconet hops randomly through the available frequencies, so all of the piconets are completely separated from one another. (Courtesy: www.howstuffworks.com)

Advantages of Bluetooth

The advantages of Bluetooth are:

1. It provides a new global standard for data and voice
2. Eliminates cables
3. Low Power, Low Range, Low Cost
4. Master Slave relationship can be adjusted dynamically.
5. Adaptive.
6. No need for Line of sight

What is Bluejacking?

Since, Bluetooth is a radio wireless technology that allows computers, cell phones, laptops, etc. to exchange or talk to each other in a limited range. Hijacking via Bluetooth is called Bluejacking. It refers to sending unnecessary and anonymous messages by using bluetooth enabled devices as a contact. In order to carry out bluejacking, both devices should be bluetooth enabled and should be within 10 metres of each another. Phone owners who receive bluejack messages should refuse to add those contacts to their address book.

Wi-Fi

Wi-Fi stands for Wireless Fidelity. It is a wireless-based transmission of Internet signals in a form of a radio wave at spot frequency of 2.4 or 5 GHz at a high speed of 11 million bits per second within a range of 100 meters. Within this range, all Wi-Fi enabled computers will be able to access the Internet without any wires, thereby setting up a Wireless Local Area Network (WLAN). The cost effective Wi-Fi technology is being

-: About this document:-

installed in airports, libraries and business organizations. The real significance of Wi-Fi based WLAN technology is its free network movement.

WiMax

WiMax stands for Wireless Interoperability Microwave Access. A faster version of Wi-Fi, WiMax is a wireless technology that offers a faster broadband connection at longer distances of up to 50 kms. The radius of WiMax coverage is measured in square kilometres unlike Wi-Fi, which is measured in square metres.

WiMAX (Worldwide Interoperability for Microwave Access) is a telecommunications protocol that provides fixed and mobile Internet access. WiMAX has the potential to do to broadband Internet access what cell phones have done to phone access. In the same way that many people have given up their "land lines" in favor of cell phones, WiMAX could replace cable and DSL services, providing universal Internet access just about anywhere we go. WiMAX will also be as painless as WiFi as turning a computer on will automatically connect to the closest available WiMAX antenna.

- 👉 WiMax delivers low cost, open networks and is the first of all IP mobile internet solution enabling efficient and scalable networks for data , video and voice transmission thus is counted in 4G.
- 👉 WiMax is IP based, wireless broadband access technology that provides performance similar to the Wi-Fi networks.

Broadband Wireless Spectrum

Airwaves that enable access to faster internet data at download rates as high as 6-10 MBPS via the wireless medium. Basically, customers can access streaming videos. Technologies such as WiMax, **Long-Term Evolution (LTE)** and Flash-OFDMA support such networks. In India, spectrum winners are expected to use LTE and WiMax. The benefits are improved and faster internet connectivity on the move. To help people in remote and hilly areas, where wire line broadband is out of reach. E-governance and m-commerce will be easier.

Long-Term Evolution (LTE)

LTE is a 4G technology yet to be introduced globally on which companies like Qualcomm plan to offer services. LTE offers speeds up to 100 MBPS, ideal for high-intensity business web access.

LTE v/s WiMax

Please note that Both WiMAX and LTE are 4G cellular broadband networks. The WiMAX provides speed up to 128 mbps of downloading and for uploading it provides the speed of 56 mbps. However, LTE showed an early implementation speed up to 100 mbps downloading and 50 mbps uploading.

Right now there is an epic battle going on between LTE and WiMAX for 4G supremacy, however, neither of these technologies has emerged as victorious over the other. Please note that WiMAX is developed by the IEEE, while LTE is a proprietary model developed by mobile carriers and equipment vendors. WiMAX is open standard and cheaper instrument.

It seems as though both technologies will become viable 4G access technologies, while WiMAX still maintains its position as an ideal backhaul technology as well. Now, some will claim that either WiMAX or LTE must win from an access perspective, but more and more, that does not seem to be the case.

However, WiMax loses some of its sheen because of the high device costs and absence of VoIP. 3G networks also promise faster data speeds. Exorbitant WiMax fees may make winners price the services at a premium. Seamless connectivity challenges with CDMA devices may prove to be a disadvantage.

- 👉 Next Documents is on **Communication and Earth Observation Satellites**.

-: About this document:-